

A2TPMI[®] Datasheet

Thermopile with integrated signal processing circuit.
Rev. June 2006

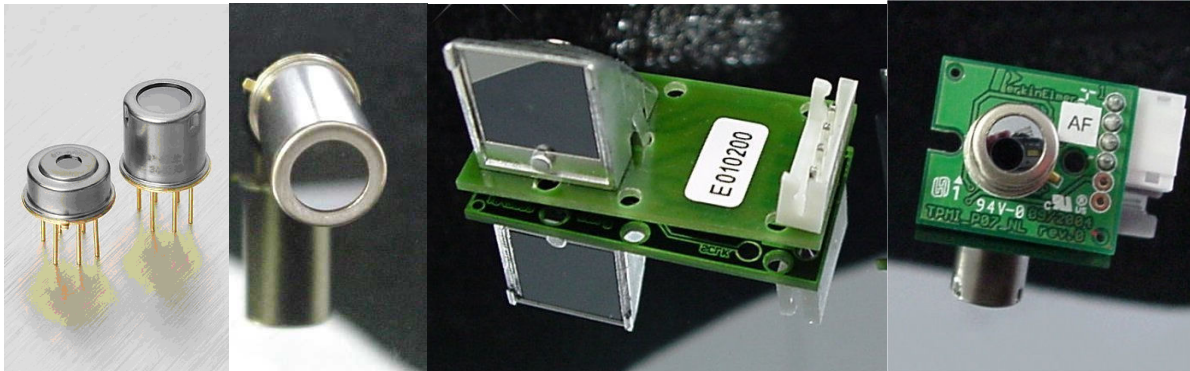

Description

The PerkinElmer A2TPMI[®] is a versatile infrared thermopile sensor with an integrated configurable ASIC for signal processing and ambient temperature compensation. This integrated infrared module senses the thermal radiation emitted by objects and converts this to an analog voltage.

The A2TPMI can be delivered fully factory calibrated and adapted to the customer specification, as well as customer programmable via the serial interface. In the pre-calibrated version, only three pins are necessary for operation: object output voltage, 5 V supply voltage, and ground.

As described in the specification, the temperature accuracy of the fully adjustable integrated circuit outperforms that of the previous PerkinElmer thermopile modules with discrete components on pcb, because the A2TPMI features an offset correction of the amplifier and a factory calibrated ambient temperature sensor. This makes the A2TPMI a versatile, compact and high precision device.

Due to the internal digital signal processing and 8 bit resolution of the internal control registers the A2TPMI has improved accuracy for adjustment and improved performance. E²PROM technology allows unlimited changing of the configuration.

For amplification of the highly sensitive thermopile signal in the micro- to millivolt range, a high resolution programmable low noise chopper amplifier is provided. An adjustable high precision ambient temperature sensor followed by a signal processor, offers an accurate compensation signal with polynomial characteristics that perfectly matches that of the thermopile's output. Adding of these signals results in an ambient independent object temperature signal over a large temperature range, which can still be adapted / scaled to customer needs due to flexible offset and post gain adjustment facilities of the device.

The two configurable comparators of the A2TPMI that can alternatively be used enhance the functionality. This allows to employ the A2TPMI as a temperature dependent switch for alarm purposes. Threshold temperatures and the hysteresis is free programmable for both comparators.

Due to integration of sensor and electronic in a compact TO-39 housing, the A2TPMI is robust and insensitive to environmental influences like pcb contamination (leakage currents), humidity and electromagnetic interference.

Features and Benefits

- Smart thermopile sensor with integrated signal processing.
- Can be adapted to your specific measurement task.
- Integrated, calibrated ambient temperature sensor.
- Output signal ambient temperature compensated.
- Fast reaction time.
- Different optics and IR filters available.
- Digital serial interface for calibration and adjustment purposes.
- Analog front end / back end, digital signal processing.
- E²PROM for configuration and data storage.
- Configurable comparator with high / low signal for remote temperature threshold control.
- TO-39 6-pin housing.

Applications

- Miniature remote non-contact temperature measurement (pyrometer).
- Temperature dependent switch for alarm or thermostatic applications.
- Residential, commercial, automotive, and industrial climate control.
- Household appliances featuring a remote temperature control like microwave oven, toaster, hair dryer.
- Temperature control in laser printers and copiers.
- Automotive climate control.

Table of Contents

TPMI® Ordering Information	4
Some Standard PerkinElmer TPMI configurations:	5
Functional Diagram	5
Labeling	6
Absolute Maximum Ratings	6
Electrical Characteristics	7
AC Characteristics	7
Thermopile Characteristics	7
V_{Tobj} / V_{Tamb} Characteristics	7
Optical Characteristics	8
Filter Characteristics	9
General Description	9
Thermopile Sensor	9
Ambient Temperature Sensor	9
Ambient Temperature Compensation	10
Control Unit / Serial Interface	10
Output Configuration	10
Application Information	11
Ambient Temperature Compensation	11
Measurement Tolerance	11
Output Signal	12
Printed Circuit Board (PCB) Version	12
Output Load	13

Response Time	13
Latch-up Avoidance	13
Soldering	13
Packaging Information	14
PCB Version P6 J4S	15
PCB Version P6 J4T	15
PCB Version P6 J4S and P6 J4T with External Mirror	16
PCB Version P7 J4S	17
PCB Version P7 J4T	17
Connection Information	18
Liability Policy	19

TPMI[®] Ordering Information

example	A2	TPMI	334	L5.5	OAA	100	P1L	MLG12	J6T
Part code:	sn	TPMI	n3c - xxx - Gxx	Oxx	nnn	Pnx	Mx(e)Gxx	xxxx	
Series (sn) A2 analog ASIC - version 1									
TPMI - TO 39 housing - 5 isolated pins, 1 ground pin to housing - internal ASIC for signal conditioning									
Sensor chip and cap (n3c) chip: n = 2 0.5 mm diameter absorber n = 3 0.7 x 0.7 mm ² absorber (standard) digit "3": temperature reference included (standard for TPMI) cap: c = 4 standard cap, window diameter 2.5 mm, fov = 60° / lens cap of various lengths c = 6 high cap, additional internal optics, e.g. internal reflector (IR) c = 7 square hole 3.5 x 3.5 mm ² , low cap, large fov = 100° c = A aluminium cap									
Sensor optics (xxx) blank standard filter with 5.5 µm cut-on wavelength L-x.y silicon lens with x.y mm focal length IRA internal reflector (mirror) A internal aperture FL-x.y fresnel lens with x.y mm focal length FOV x field of view = x°									
Infrared filter on sensor (Gxx) blank standard filter with 5.5 µm cut-on wavelength G9 pyrometry filter, 8..14 µm bandpass Gxx PerkinElmer specified broadband or (narrow) bandpass filter									
Output configuration (Oxx) Pin V_{Tobj} A ambient temperature compensated output voltage representing object temperature B not compensated output voltage C comparator 1 enabled Pin V_{Tamb} A output voltage representing ambient (sensor) temperature V V _{ref} = 1.225 V C comparator 2 enabled									
Temperature sensing range (n) nnn -20 ... nnn °C (remark: for object T range < 100 °C the min. T-range may be >20 °C)									
Option: Printed circuit board (pcb) P6 standard pcb 17 x 33 mm ² P7 mini pcb 17 x 20 mm ² L1 or L2 electrical low pass filter on pcb (L1 = 1st order with RC; L2 = 2nd order with OpAmp)									
Option: External optics and filter ML/MR/MF(e) mirror left / right / front looking (external filter not glued) G standard filter glued to mirror Gxx PerkinElmer specified broadband or (narrow) bandpass filter glued to mirror									
Option: Connector blank none WTB wire to board I / JxT I = customer specific connector / J = standard JST connector, x = no of pins, top entry I / JxS I = customer specific connector / J = standard JST connector, x = no of pins, side entry I / JxxC with counterpart									

Some Standard PerkinElmer TPMI configurations:

Device	Object temperature range	Field of view and optics	pcb and connector	Applications
A2TPMI334 OAA060 / 6259	-20...60 °C	60° fov aperture optics	no pcb	Automotive anti-fogging, air conditioner, room thermostat, thermal management of close objects
A2TPMI334-L5.5 OAA060 / 6266	-20...60 °C	7° fov lens optics	no pcb	Precise low temperature sensing
A2TPMI334-L5.5 OAA120 / 6267	-20...120 °C	7° fov lens optics	no pcb	Mini-pyrometer
A2TPMI 334 OAA140 P6L1 MLG12 J4T / 6261	-20...140 °C	7° fov external mirror optics	P6, 4 pin top entry	Microwave oven
A2TPMI334-L5.5 OAA250 / 6265	-20...250 °C	7° fov lens optics	no pcb	Mini-pyrometer
A2TPMI 334-L5.5 OAA250 P7L1 J4S / 6290	-20...250 °C	7° fov lens optics	P7, 4 pin side entry	Printer / Copier

These standard devices are usually available ex stock. The 4 digit number after the device name denotes PerkinElmer order number. Please also check for our TPMI selection guide for more details.

For data visualization and for configuration changes a versatile application kit with PC software is available. Please ask for details.

Functional Diagram

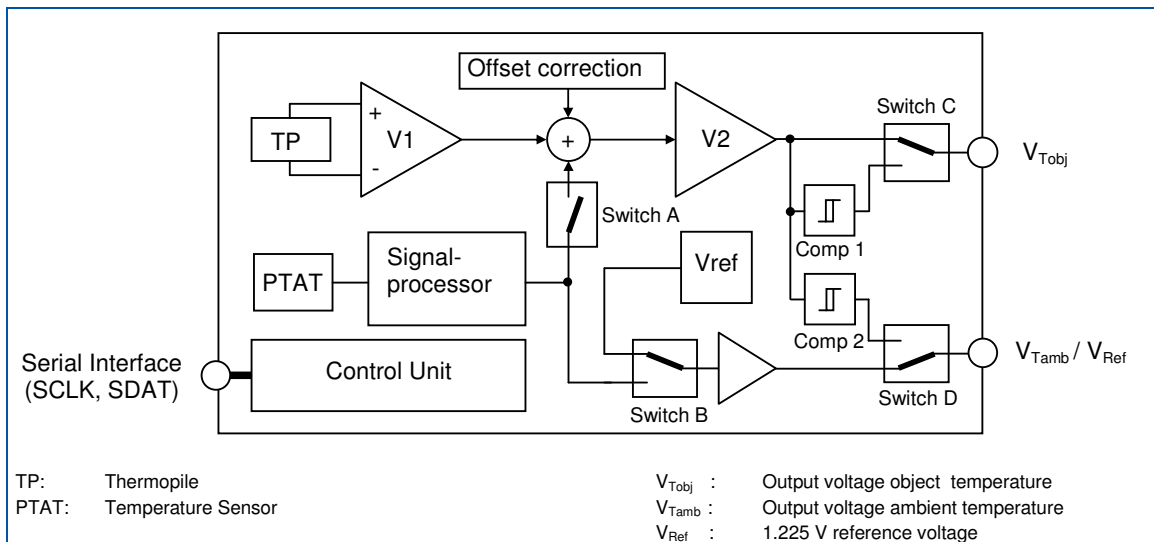

Labeling

Sensor:

SSSS	Last four digits of the device part number
XYX	X = Last digit of the calendar year, YY = Week of the calendar year
HHH	Serial number of the production lot
AA	Calibration encoding

Example:

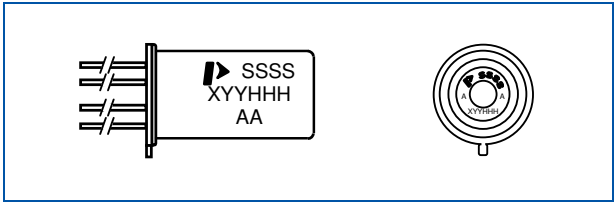

PCB Version:

Sensors assembled on a PCB are labeled with a sticker with a letter and a serial number printed on. The letter describes the manufacturing site as follows:

H	Production parts made in Germany
B	Production parts made in Indonesia
E	Engineering samples

Absolute Maximum Ratings

Parameter	Min	MAX
Supply voltage V_{DD}	-0.3 V	+6.5 V
Storage temperature range ^{Note 1)}	-40 °C	100 °C
Operating temperature range	-25 °C	100 °C
Voltage at all inputs and outputs ^{Note 2)}	-0.3 V	$V_{DD} + 0.3 V$
Current at input pins ^{Note 2)}		+/- 5 mA
Lead temperature (Soldering, 10 sec)		+300 °C
ESD tolerance ^{Note 3)}		2.5 kV

Note 1: Extension to 120 °C for limited periods of several minutes possible.

Note 2: Limiting input pin current is only necessary for input voltages that exceed absolute maximum input voltage ratings.

Note 3: Human body model, 1.5 kΩ in series with 100 pF. All pins rated per method 3015.7 of MIL-STD-883.

Static-sensitive device. Unused devices must be stored in conductive material. Protect devices from static discharge and static fields. Stresses above those listed under “Absolute maximum ratings” may cause permanent damage to the device. Exposure to absolute maximum rating conditions for extended periods may affect device reliability.

Precautions should be taken to avoid reverse polarity of power supply. Reversed polarity of power supply results in a destroyed unit.

Do not expose the sensors to aggressive detergents such as freon, trichlorethylen, etc. Optical windows (e.g. filter, lens) may be cleaned with alcohol and a cotton swab.

Electrical Characteristics

Symbol	Parameter	Min	Typ	Max	Unit	Conditions
Power Supply						
V _{DD}	Supply Voltage	4.5	5	5.5	V	
I _{DD}	Supply Current		1.5	2	mA	R _L > 1 MΩ
Outputs V_{Tobj} / V_{Tamb}						
VO	Output Voltage Swing	0.25		V _{DD} - 0.25 V	V	I _{out} : -100 μA ... +100 μA
RO	Output Resistance			100	Ω	
RL	Resistive Output Load	50			kΩ	
CL	Capacitive Output Load		100	500	pF	
ISC	Output short circuit current		6		mA	Sourcing
			13		mA	Sinking
Serial Interface SDAT, SCLK						
V _{iL}	Low level input voltage			0.3 V _{DD}	V	
V _{iH}	High level input voltage	0.7 V _{DD}			V	
I _{iL}	Low level input current	-600		-200	μA	
I _{iH}	High level input current			1	μA	
V _{oL}	Low level output voltage			0.5	V	Output current ≤ 2 mA
V _{oH}	High level output voltage	V _{DD} - 0.6 V			V	Output current ≥ -2 mA
Reference Voltage						
V _{Ref}	Reference voltage	1.223	1.225	1.227	V	R _L > 1MΩ, T _{amb} = 25 °C
TC _{VRef}	Temperature coefficient of reference voltage		±30	±100	ppm K ⁻¹	

Unless otherwise indicated, all limits specified for T_{amb} = 25 °C, V_{DD} = +5 V

AC Characteristics

Symbol	Parameter	Min	Typ	Max	Unit	Conditions
I _N	V1 Input referred voltage noise			120	nV/√Hz	rms value
t _{strt}	Response time after power on			1	s	
t _{lat}	Latency time for V _{Tobj}			75	ms	
t _{resp}	Response time		90	150	ms	

Unless otherwise indicated, all limits specified for T_{amb} = 25 °C, V_{DD} = +5 V

Thermopile Characteristics

Symbol	Parameter	Min	Typ	Max	Unit	Conditions
3-type chip (TPS 33x)						
S	Sensitive (absorber) area		0.7 x 0.7		mm ²	
N	Noise voltage		38		nV/√Hz	
τ	Time constant		25		ms	

V_{Tobj} / V_{Tamb} Characteristics

The V_{Tobj} and the V_{Tamb} characteristics of thermopile sensors depend not only on object and ambient temperature but on several other factors like object size to spot size relation, ambient temperature compensation behaviour or optical filter characteristics. Therefore it is not possible to specify a general V_{Tobj} and V_{Tamb} characteristic. Those characteristics will be specified application specific in a separate customer specification.

Optical Characteristics

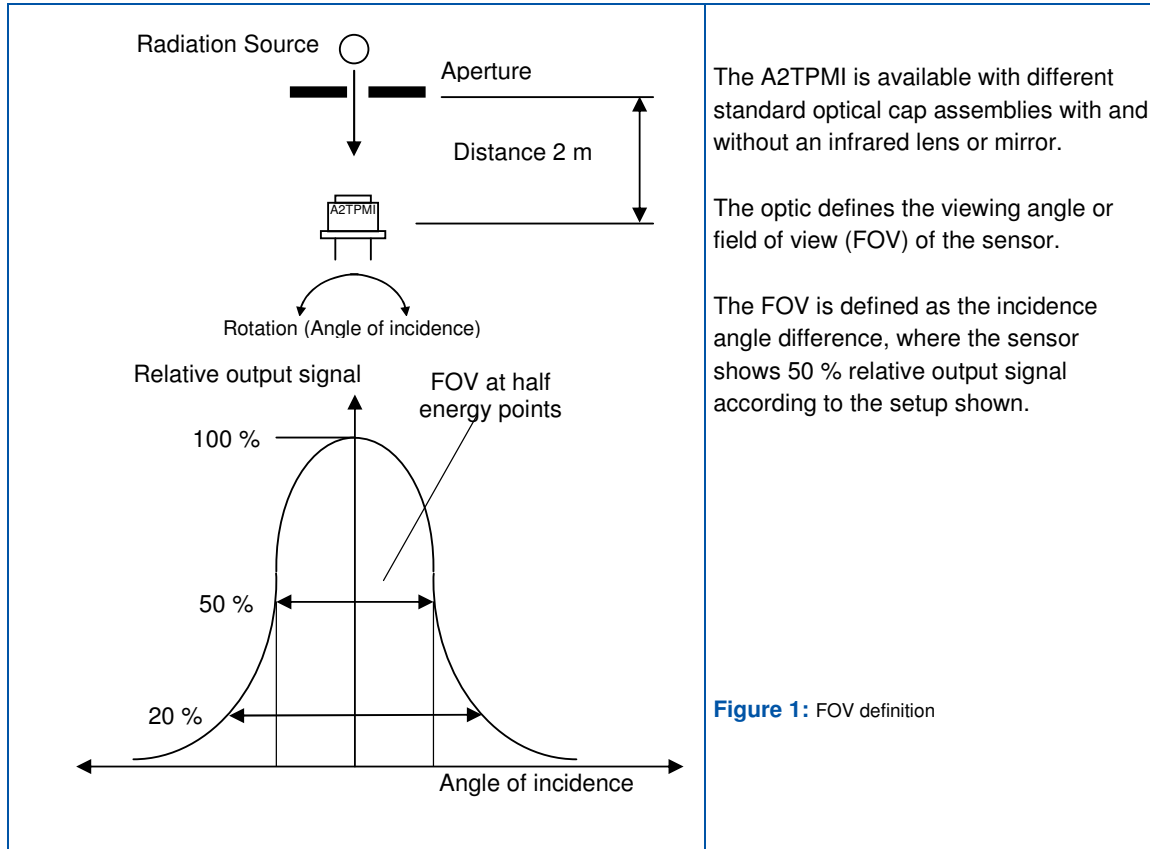

The A2TPMI is available with different standard optical cap assemblies with and without an infrared lens or mirror.

The optic defines the viewing angle or field of view (FOV) of the sensor.

The FOV is defined as the incidence angle difference, where the sensor shows 50 % relative output signal according to the setup shown.

Figure 1: FOV definition

Symbol	Parameter	Min	Typ	Max	Unit	Conditions
Standard Cap Type (C4)						
FOV	Field of view		60	70	°	50 % rel. output signal
OA	Optical axis		0	± 10	°	in reference to symmetrical axis of cap
High Cap Type with Internal Reflector (C6 IRA)						
FOV	Field of view		15	20	°	50 % rel. output signal
OA	Optical axis		0	± 2	°	in reference to symmetrical axis of cap
Low Cap Type (C7)						
FOV	Field of view		100	105	°	50 % rel. output signal
			125	135	°	10 % rel. output signal
OA	Optical axis		0	± 10	°	in reference to symmetrical axis of cap
Mirror Module (ML / MR / MF)						
	Field of view		7	12	°	50 % rel. output signal
Lens Cap Type (L5.5)						
FOV	Field of view		7	12	°	50 % rel. output signal
OA	Optical axis		0	± 3.5	°	in reference to symmetrical axis of cap
D:S	Distance to spot size ratio		8 : 1			
Lens Cap Type (L10.6)						
FOV	Field of view		5	8	°	50 % rel. output signal
OA	Optical axis		0	± 2	°	in reference to symmetrical axis of cap
D:S	Distance to spot size ratio		11 : 1			

Filter Characteristics

Parameter	Min	Typ	Max	Unit	Conditions
Standard Filter					
Average Transmission	70			%	Wavelength range from 7.5 μm to 13.5 μm
Average Transmission			0.5	%	Wavelength range from visual to 5 μm
Cut On	5.2	5.5	5.8	μm	At 25 °C
G9 Filter					
Average Transmission	70			%	Wavelength range from 9 μm to 13 μm
Average Transmission			1	%	Wavelength range from visual to bandpass
Cut On	7.8	8	8.2	μm	At 25 °C
Uncoated Silicon Lens (G12)					
Average Transmission		52		%	Wavelength range from 5.5 μm to 13.5 μm

PerkinElmer offers a wide range of Infrared Filters available in many different filter characteristics. Please contact PerkinElmer if you have special requirements or need further information.

General Description

Thermopile Sensor

The signal voltage, generated by the infrared radiation-sensitive thermopile sensor, is preamplified by a programmable chopper amplifier with 8 bit resolution.

Due to the principle of thermopile temperature measurement, the thermopile voltage can be positive or negative depending on if the object temperature is higher or lower than the ambient temperature of the A2TPMI. In order to allow signal processing of negative voltages with a single supply system, all internal signals are related to an internal voltage reference (V_{ref}) of nominal 1.225 V, which serves as a virtual analog ground.

For offset voltage trimming of the thermopile amplification path, the preamplifier is followed by a programmable trimming stage generating an offset voltage with a resolution of 8 bit.

The thermopile voltage shows a non-linear output characteristic versus the object temperature.

Ambient Temperature Sensor

The temperature of the A2TPMI, respectively the thermopile sensor, is detected by an integrated temperature sensor. This signal will be amplified and signal processed in order to match the reverse characteristics of the amplified thermopile curve, to realize an optimum of ambient temperature compensation after adding the two signals. The characteristics of the temperature sensor signal is adjustable. This adjustment is part of the ASIC production process and will be provided by PerkinElmer. Thus the characteristics of the A2TPMI ambient temperature signal V_{Tamb} is always provided fully calibrated.

Ambient Temperature Compensation

The thermopile sensor converts the temperature radiation of an object surface to an electrical signal by means of thermocouples (Seebeck effect). The sensor output voltage is caused by the temperature difference between radiation heated (hot) junctions and cold junctions with a good thermal contact to the housing.

In order to deliver an output signal which is only dependent on the object temperature, any change of housing (ambient) temperature has to lead to an appropriate output signal correction.

For temperature compensation, the amplified thermopile- and temperature reference signals ($V_{T_{ambint}}$) are added in an adding amplifier stage. The amplification is adjustable in a wide range according to application / customer requirements.

The ambient temperature compensated and amplified signal is supplied to the output $V_{T_{obj}}$. The temperature reference signal or alternatively the band gap reference voltage is available on a second output pin $V_{T_{amb}}$. Both outputs are short circuit stable.

Control Unit / Serial Interface

The operation characteristics of the A2TPMI have to be configured with a set of internal random access registers. All parameters / configurations are permanently stored in E²PROM in parallel; configuration is usually done during factory calibration and does not need any user input.

The control unit offers access to all the registers via serial interface, i.e. the internal parameters of the A2TPMI. The serial interface is a two wire bi-directional synchronous (SDAT, SCLK) type. A2TPMI sensors are in general factory calibrated and therefore there is no need to use the serial interface for standard applications.

The SDAT- / SCLK pins are internally pulled up to VDD and can be left unconnected. If the SDAT / SCLK pins will be connected in the application, ensure signal conformity to the serial interface specification. Subsequent undefined signals applied to these pins may change the configuration and lead to malfunctioning of the sensor.

For detailed information about the serial interface refer to application note: *A2TPMI[®] Serial Interface*, or contact the PerkinElmer application support.

Output Configuration

The A2TPMI offers various output configurations, which can be configured via the serial communication interface by means of integrated analog switches. For each output it can be individually selected whether the output operates in 'Analog mode' or in 'Comparator mode'.

In 'Analog mode' the output signal represents the measured IR radiation, or rather the temperature as an analog DC voltage.

In 'Comparator mode' the measured IR radiation, or rather the temperature is compared to a programmed threshold. For slowly changing signals an additional hysteresis can be configured. If the measured signal is above the threshold, +5 VDC (logical high) is applied to the output. If the measured signal is below the threshold, 0 VDC (logical low) is applied to the output.

For detailed information about the output configuration refer to application note: *A2TPMI[®] Serial Interface*, or contact the PerkinElmer application support.

Application Information

Ambient Temperature Compensation

Because of many physical effects that influence the non-contact temperature measurement based on infrared radiation, it is difficult to meet the best initial adjustment for a specific application. Therefore some deviations might be found at first measuring. For all applications the optimized solution can be prepared and fixed based on the measurement in the application environment. PerkinElmer will be pleased to assist you in finding the conditions, which deliver the highest accuracy in your application.

The temperature compensation is only working well within a certain ambient temperature range, limited by different device parameters of the thermopile sensor and the temperature reference sensor. The following diagram shows the typical characteristics and is only an example in order to better understand the principle compensation curve. The curve shows the deviation for a compensated module that functions correctly.

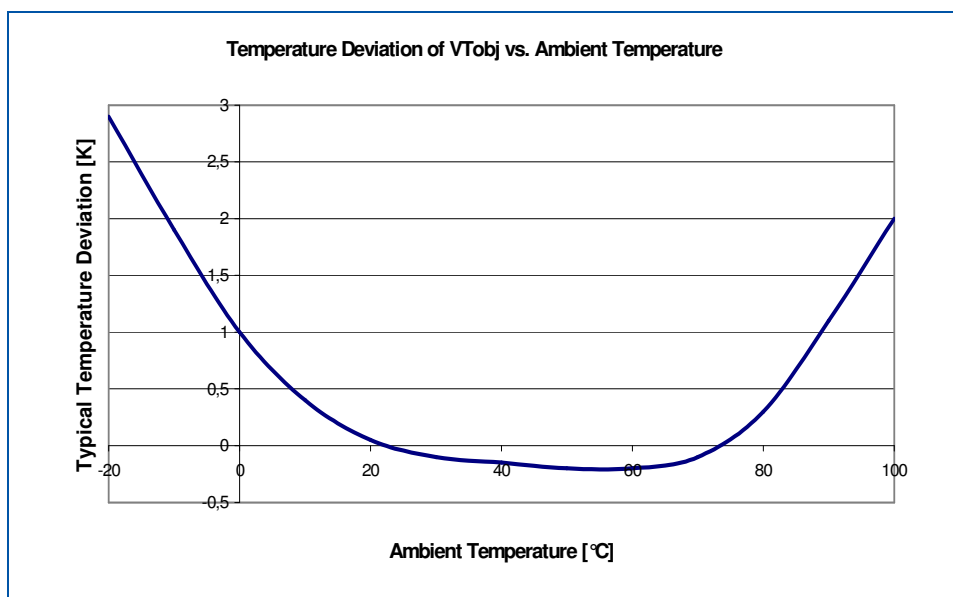

Figure 2

The compensation of the module sample in the diagram is adjusted to the best fitting at 20° C to 80° C ambient temperature, but the curve can be shifted in the whole ambient temperature range through the change of A2TPMI parameters.

Measurement Tolerance

The temperature error of the A2TPMI depends on several factors like the emissivity, object temperature, object size to spot size relation, temperature gradients over the sensor housing in the environment, device tolerances and the optimal adjustment of the ambient temperature compensation.

The accuracy as specified under V_{Tamb} and V_{Tobj} characteristics is based on theoretical calculation as well as on statistical evaluation results. The PerkinElmer quality system ensures that all A2TPMIs are calibrated and tested under certain test conditions in order to guarantee these specifications.

However, due to the nature of infrared remote temperature measurements there might be deviations or limits that are exceeded in specific application environments. In this case please contact the PerkinElmer application support to help you solve the problem.

Output Signal

The A2TPMI amplifiers are implemented in chopper amplifier technology. Due to the nature of this technology the output signals V_{Tobj} and V_{Tamb} incorporate an AC signal of approximately 10 mV peak to peak in the range of 250 kHz. This AC voltage can be suppressed either by an electrical low pass filter or via an additional software filtering.

In applications with low resistive load (> 1 MOhm) a simple RC low pass filter as described below can be used to smooth the signal:

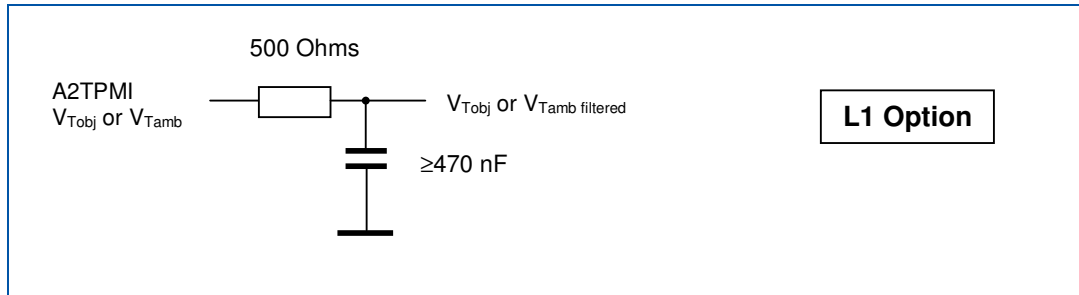

In applications with high resistive load (50 kOhm ... 1 MOhm) filtering can be achieved with the following circuit. A rail to rail OPamp like the LMV358 should be used so that the full sensing range will be available on the output of the filter circuit.

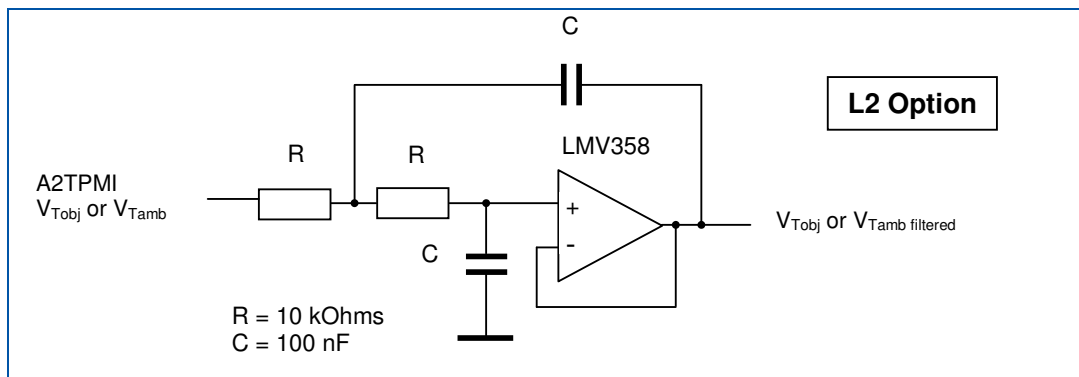

Printed Circuit Board (PCB) Version

Two different sizes of standard PCB versions are available. The P6 version is a 17 x 33 mm² PCB which allows assembly of additional external mirror optics (M options). The P7 version is a 17 x 20 mm² PCB suitable for applications with restricted space. The P7 version is not available with a mirror (M option).

Each PCB version is available either as a plain version (sensor directly wired to connector), or with a 1st order (RC-circuit, L1 option), in order to provide attenuation of the AC portion on the output signal as described in the chapter Output Signal.

The PCB versions are available with following connector assemblies:

PCB / Connection type	Manufacturer: Model No.	
	Header	Connector
P6 / 4 pin top entry	JST: B 4B-EH-A	Housing: EHR 4
P6 / 4 pin side entry	JST: S 4B-EH	Contact: SEH-003T-P0.6L
P7 / 4 pin top entry	JST: B 4B-PH-K-S	Housing: PHR 4
P7 / 4 pin side entry	JST: S 4B-PH-K-S	Contact: SPH-004T-P0.5S

Note: Engineering samples will be delivered with counterpart connector with 350 mm cable.

Contact Material: Phosphor bronze ; tin-plated,
 Applicable wire: 0.032 to 0.08 mm²
 Insulation O.D.: 0.5 to 0.9 mm (PHR), 0.5 to 1.1 mm (EHR),

Output Load

Capacitive loads which are applied directly to the outputs reduce the loop stability margin. Values of 100pF can be accommodated. Resistive load for the outputs should be kept as small as possible (i.e. a large load resistance, $R_{load} > 50 \text{ k}\Omega$ has to be used) in order to avoid an impact on the temperature signal due to self heating of the module.

Response Time

The response time to an object temperature jump depends on the time constant τ of the thermopile and the signal processing time of the A2TPMI. The processing of the thermopile signal has a latency time (t_{lat}) of max. 75 ms caused by the time required for AD-conversion, DA conversion and signal processing. The following diagram explains the connection of these events

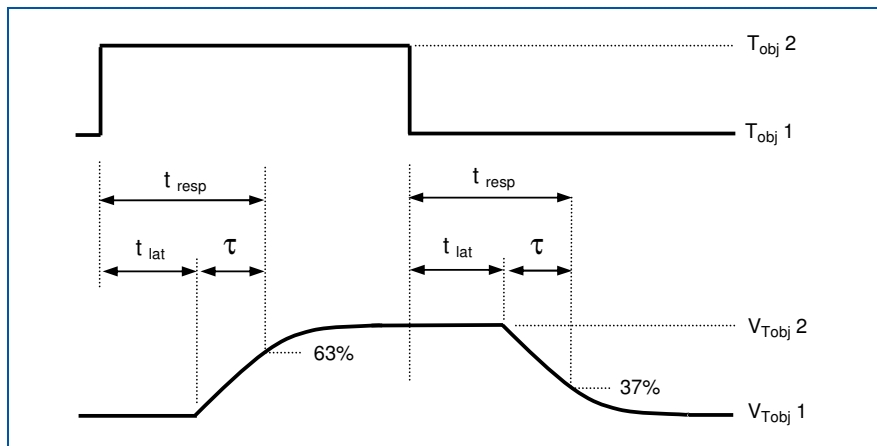

Figure 3
Response time definition

The A2TPMI has a sampling rate of 30 samples / second which results in a resolution of approx. 30 ms for dynamic signals at V_{Tobj} .

Latch-up Avoidance

Junction isolated CMOS circuits inherently include a parasitic 4-layer (PNPN) structure which has characteristics similar to a thyristor (SCR). Under certain circumstances this junction may be triggered into a low impedance state, resulting in excessive supply current, which can thermally destroy the circuit.

To avoid this condition, no voltage greater than 0.3 V beyond the supply rails should be applied to any pin. In general the A2TPMI supplies must be established either at the same time or before any signals are applied to the inputs. If this is not possible the drive circuits must limit the input current flow to maximum 5 mA to avoid latch-up. In general the device has to be operated with a 100 nF capacitor in parallel to the power supply.

Soldering

The TPMI is a lead-free component and fully complies with the RoHS regulations, especially with existing roadmaps of lead-free soldering. The terminations of the TPMI[®] sensor consist of nickel plated Kovar and gold finish. Hand soldering is recommended.

Packaging Information

<p>TO 39 with standard cap (C4): A2TPMI 334</p>	<p>TO 39 with 5.5 mm focal length Si lens (L5.5): A2TPMI 334-L5.5</p>
<p>TO 39 with high cap and int. reflector (C6 IRA): A2TPMI 336-IRA</p>	<p>TO 39 with low cap and square hole (C7) A2TPMI 337</p>
<p>TO 39 with 10.6mm focal length Si lens (L10.6): A2TPMI 334-L10.6</p>	

PCB Version P6 J4S

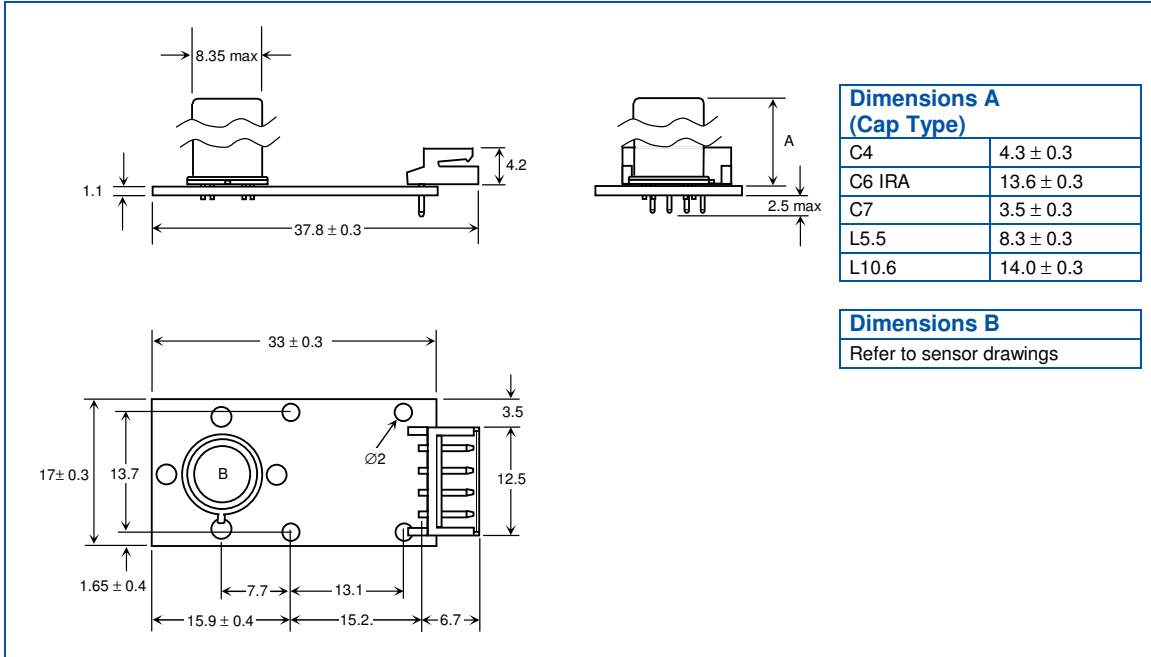

PCB Version P6 J4T

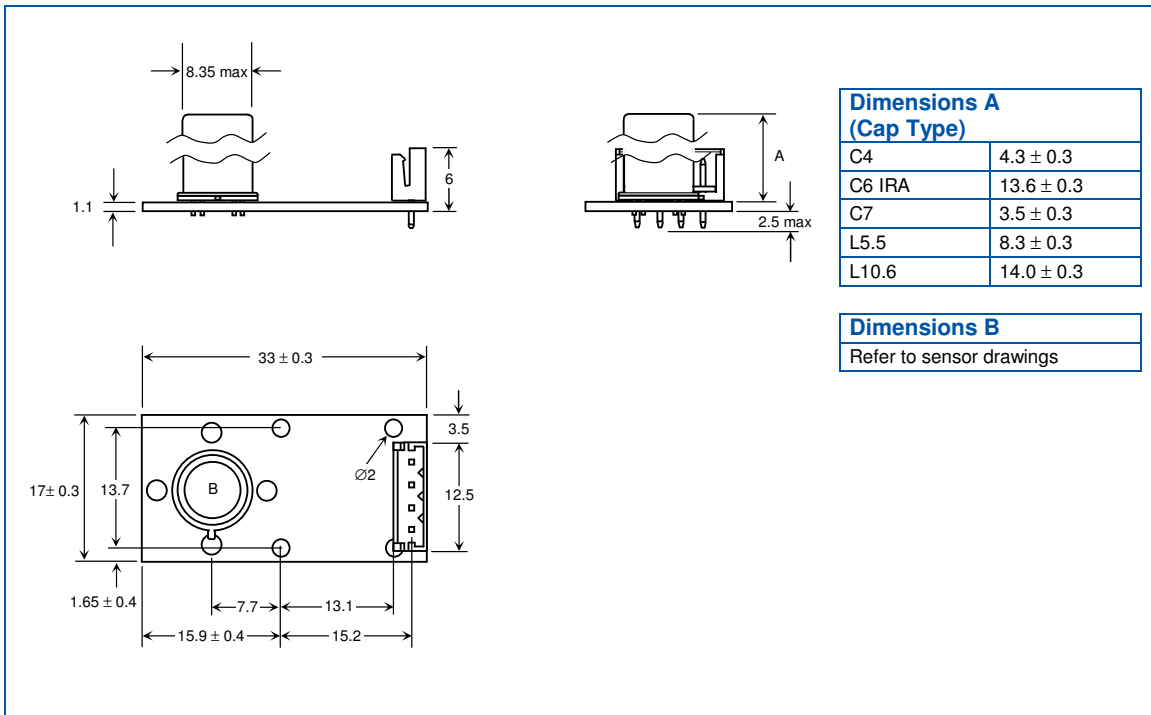

PCB Version P6 J4S and P6 J4T with External Mirror

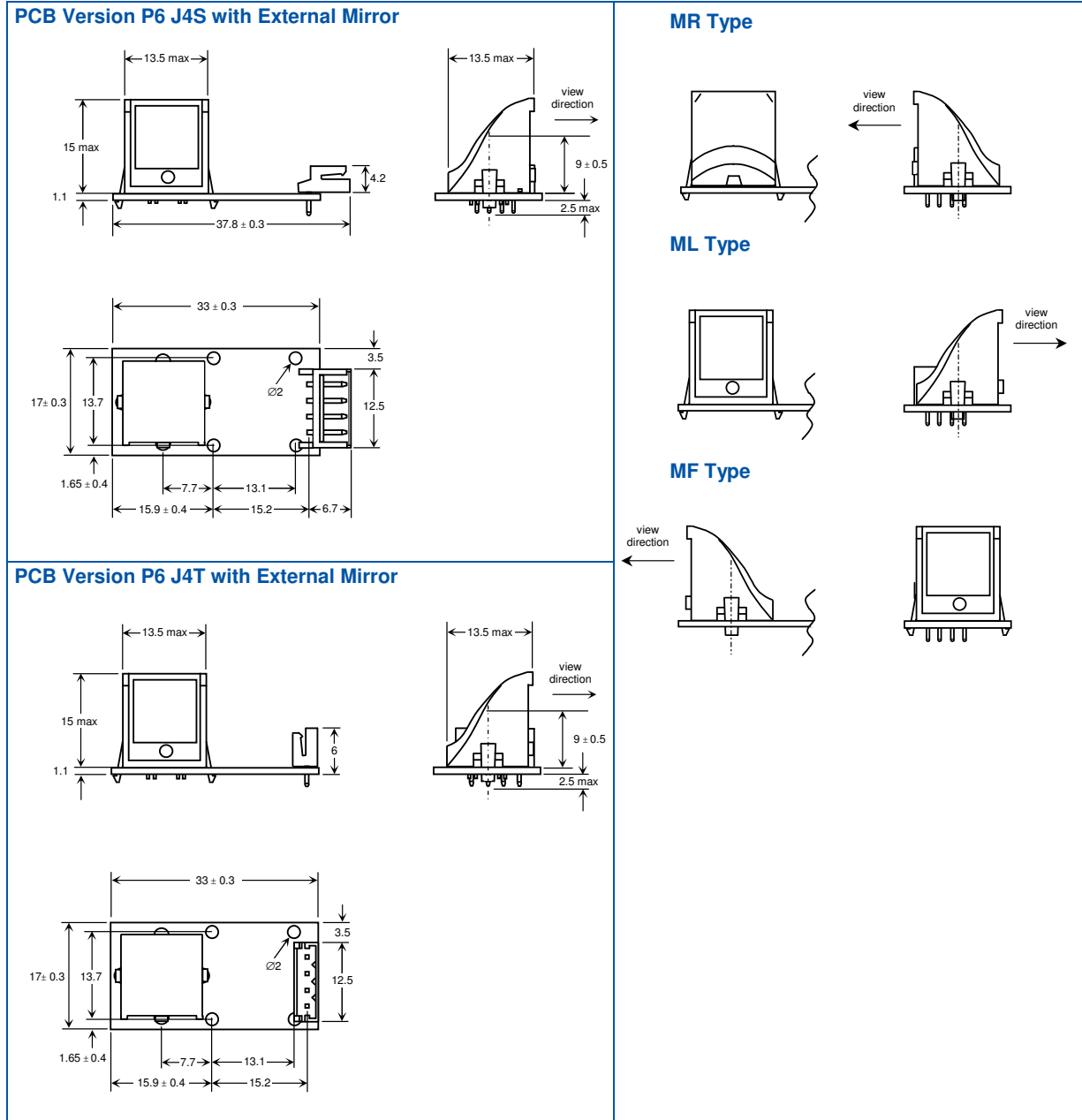

PCB Version P7 J4S

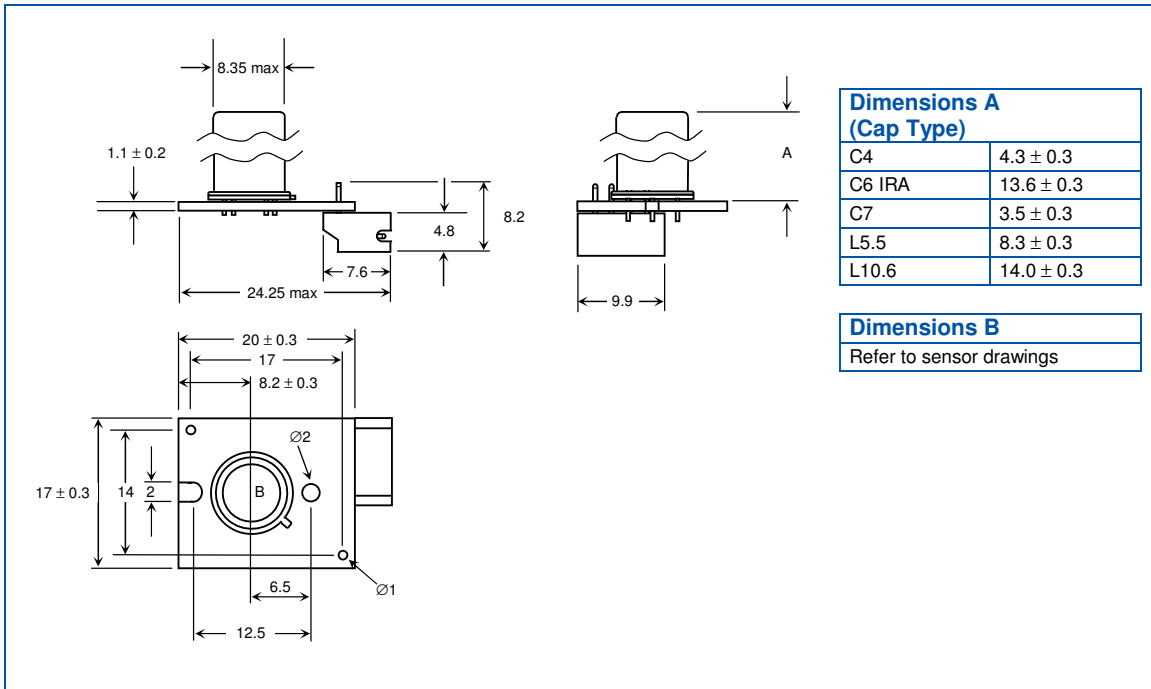

PCB Version P7 J4T

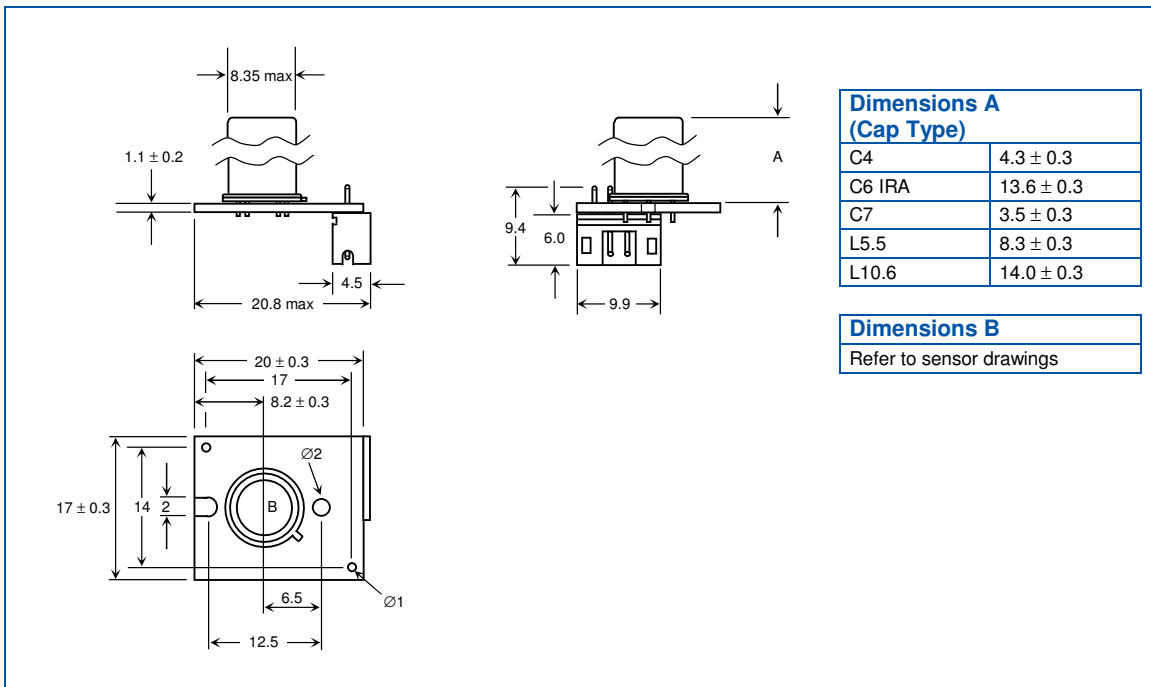

Connection Information

PCB Version P6 J4S

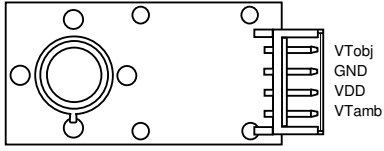

PCB Version P6 J4T

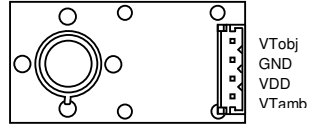

PCB Version P7 J4S

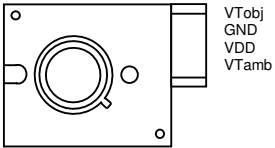

PCB Version P7 J4T

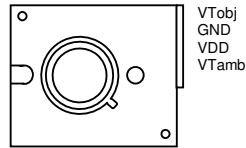

Non-PCB Version

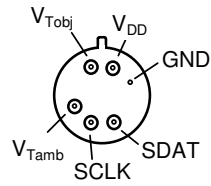

Bottom view

Liability Policy

The contents of this document are subject to change without notice. Customers are advised to consult with PerkinElmer Optoelectronics sales representatives before ordering.

Customers considering the use of PerkinElmer Optoelectronics thermopile devices in special applications where failure or abnormal operation may directly affect human lives or cause physical injury or property damage, or where extremely high levels of reliability are demanded, are requested to consult with PerkinElmer Optoelectronics sales representatives before such use. The company will not be responsible for damage arising from such use without prior approval.

As any semiconductor device, thermopile sensors or modules have inherently a certain rate of failure. It is therefore necessary to protect against injury, damage or loss from such failures by incorporating safety design measures into the equipment.

**North America
Customer Support Hub**
22001 Dumberry Road
Vaudreuil-Dorion, Québec
Canada J7V 8P7
Telephone: (+1) 450-424-3300
(+1) 866-574-6786 (toll-free)
Fax: (+1) 450-424-3345
opto@perkinelmer.com

European Headquarters
Wenzel-Jaksch-Strasse 31
65199 Wiesbaden, Germany
Telephone: (+49)611-492-247
Fax: (+49)611-492-170
opto.Europe@perkinelmer.com

Asia Headquarters
47 Ayer Rajah Crescent #06-12
Singapore 139947
Telephone: (+65)6775-2022
(+65)67704-366
Fax: (+65)6775-1008
opto.Asia@perkinelmer.com



For a complete listing of our global offices, visit www.optoelectronics.perkinelmer.com
©2005 PerkinElmer, Inc. All rights reserved. The PerkinElmer logo and design are registered trademarks of PerkinElmer, Inc. TPMI® is a trademark of PerkinElmer, Inc. or its subsidiaries, in the United States and other countries. All other trademarks not owned by PerkinElmer, Inc. or its subsidiaries that are depicted herein are the property of their respective owners. PerkinElmer reserves the right to change this document at any time without notice and disclaims liability for editorial, pictorial or typographical errors.
600101_02 DTS0606